



aerospace  
climate control  
electromechanical  
filtration  
fluid & gas handling  
hydraulics  
**pneumatics**  
process control  
sealing & shielding



# Pneumatic ISO Cylinders

P1D-LB Series  
According to ISO 15552

Catalog 0962



ENGINEERING YOUR SUCCESS.

**Features**

**Standard cylinders P1D-LB, ISO 15552**

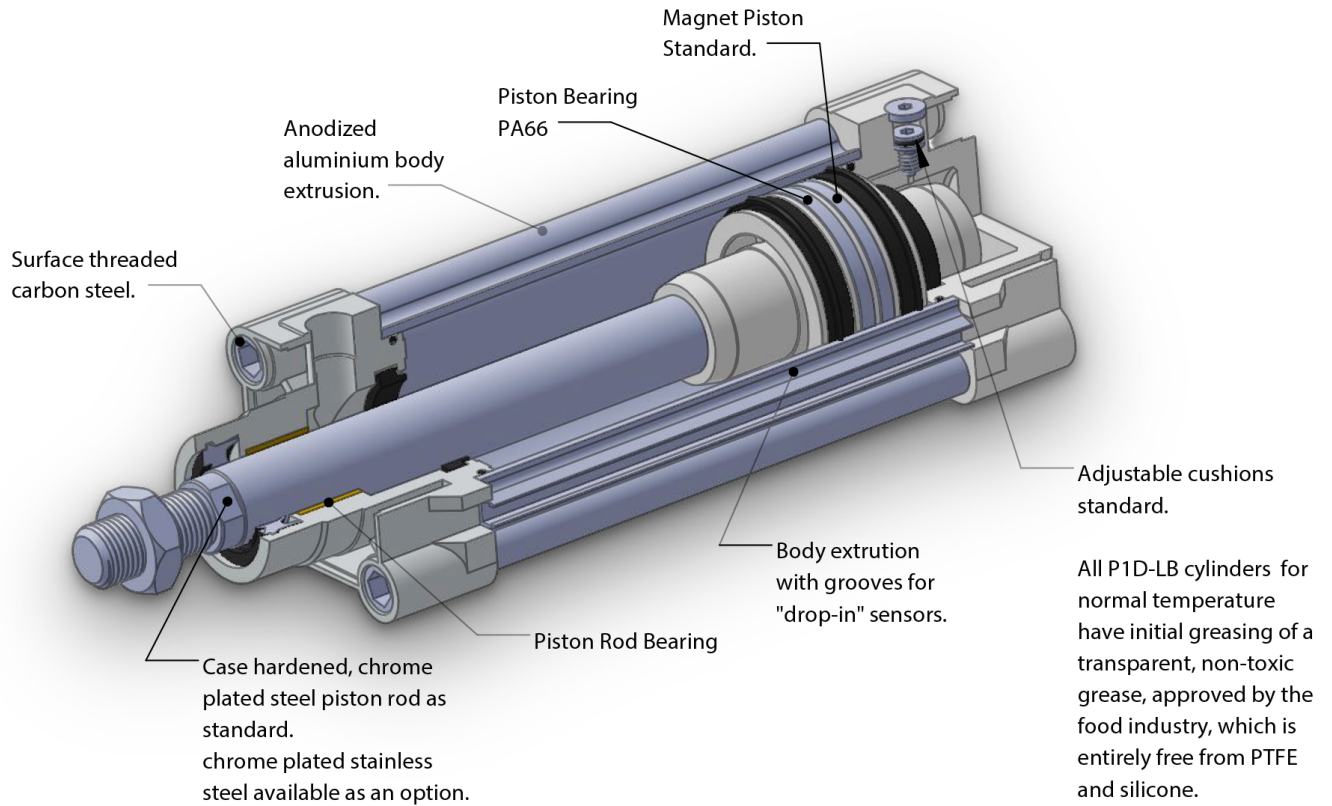

**Global product range**

The P1D-LB Series meets the specifications in the ISO 15552 standard. This means full interchangeability to any ISO 15552 cylinder anywhere around the globe. P1D-LB will be available throughout the extensive worldwide Parker Hannifin organization.

**Features**

- ISO 15552 conformity.
- Bore sizes 32-125 mm.
- Corrosion resistant design with barrel in anodized aluminium and optional stainless steel piston rod.
- Polyurethane seal technology.
- Adjustable air cushioning.
- Range of mountings available.
- Drop in global P8S-G sensors.
- Metal piston rod bearing.

**Technical Information**

**General technical data**

Product type	Standard cylinder according to ISO 15552
Bore size	32 - 125 mm
Stroke length	5-2800 mm
Versions	P1D-LB...MC
Cushioning	Adjustable air cushioning
Position sensing	Proximity sensor
Installation	P1D cylinder and piston rod mountings
Mounting position	Any

**Operating and environmental data**

**Operating medium**

For best possible service life and trouble-free operation dry, filtered compressed air to ISO 8573-1:2010 quality class 3.4.3 should be used. This specifies a dew point of +3°C for indoor operation (a lower dew point should be selected for outdoor operation) and is in line with the air quality from most standard compressors with a standard filter.

Operating pressure	0.5 bar to 10 bar
Ambient temperature Standard version	-5°C to +70°C
Pre-lubricated	Further lubrication is normally not necessary. If additional lubrication is introduced it must be continued.
Corrosion resistance	Resistance to corrosion and chemicals.

**Material specifications**

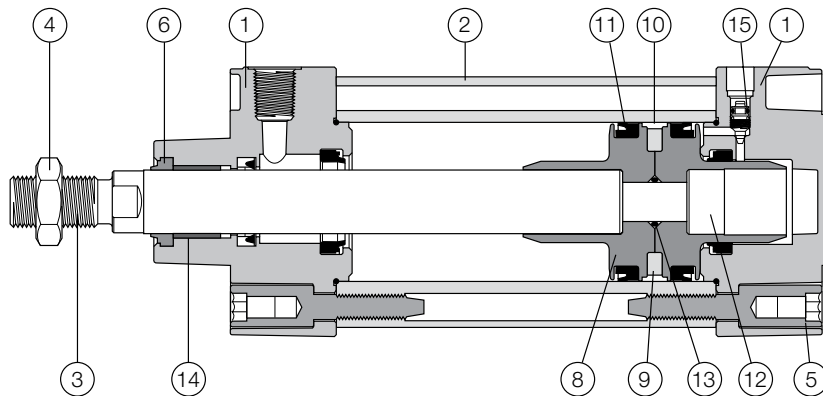

Item	Part	Specifications
1	End covers	Alloy
2	Cylinder barrel	Hard Anodized aluminium
3	Piston rod	Standard Hard chrome carbon steel
4	Piston rod nut	Carbon steel
5	End cover screws	Carbon steel
6	Scraper ring	
7	Piston rod seal	NBR
8	Piston	Aluminium Alloy
9	Magnet	RbFeB
10	Piston bearing	PA66
11	Piston seals	NBR
12	Piston bolt	Carbon Steel
13	O-rings	NBR
14	Piston rod bearing	PTFE + Brass
15	Cushioning screws	Brass
16	Cushioning seals	NBR
	Note on materials	RoHS compliant

**Order Key Code**

**Ordering Information**

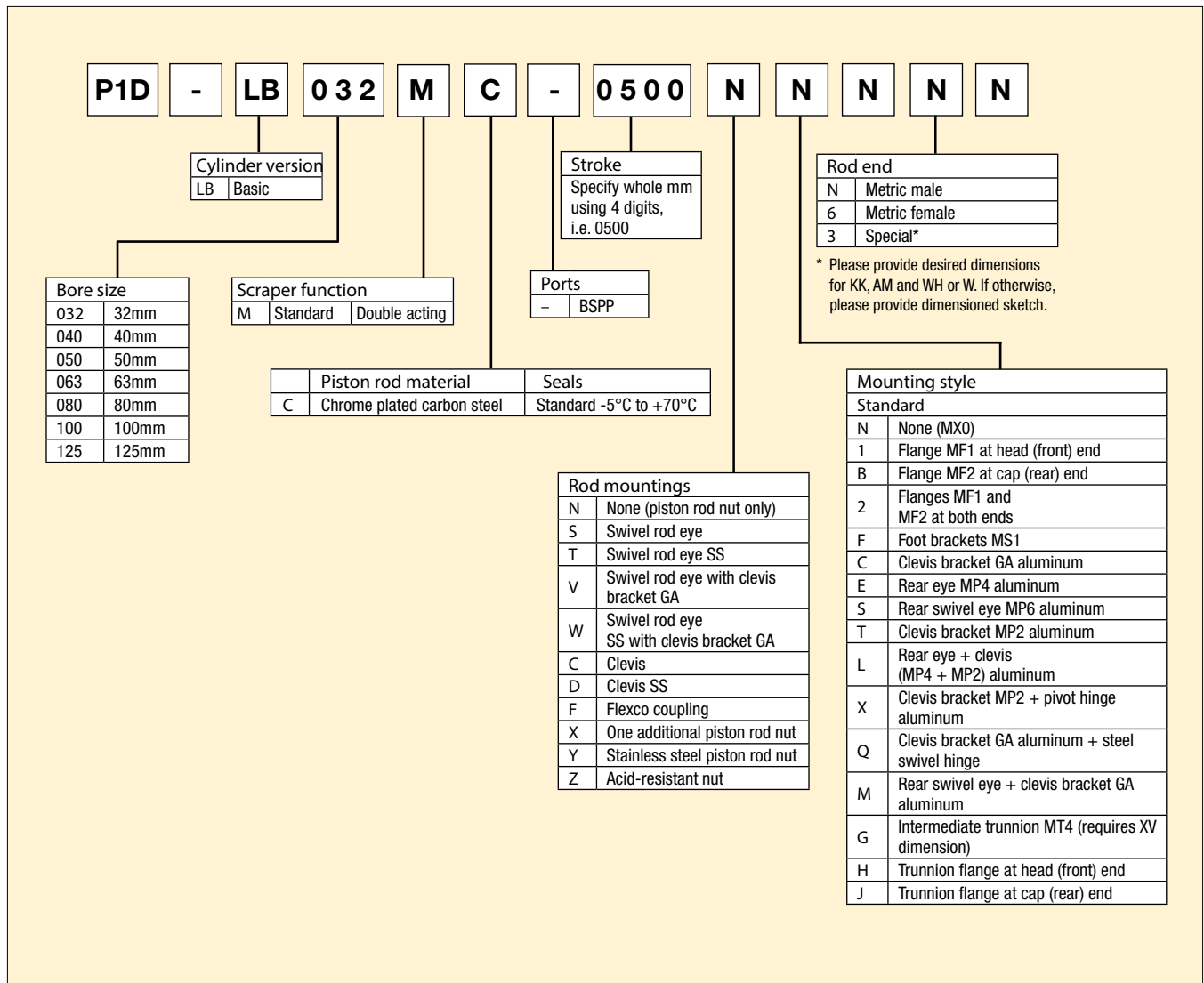

**Technical Information**

**Cylinder forces, double acting variants**

Cylinder bore / piston rod mm	Stroke	Piston cm <sup>2</sup>	Max theoretical force in N (bar)									
			1.0	2.0	3.0	4.0	5.0	6.0	7.0	8.0	9.0	10.0
32/12	+	8.0	80	161	241	322	402	483	563	643	724	804
	-	6.9	69	138	207	276	346	415	484	553	622	691
40/16	+	12.6	126	251	377	503	628	754	880	1005	1131	1257
	-	10.6	106	212	318	424	530	636	742	848	954	1060
50/20	+	19.6	196	393	589	785	982	1178	1374	1571	1767	1963
	-	16.5	165	330	495	660	825	990	1155	1319	1484	1649
63/20	+	31.2	312	623	935	1247	1559	1870	2182	2494	2806	3117
	-	28.0	280	561	841	1121	1402	1682	1962	2242	2523	2803
80/25	+	50.3	503	1005	1508	2011	2513	3016	3519	4021	4524	5027
	-	45.4	454	907	1361	1814	2268	2721	3175	3629	4082	4536
100/25	+	78.5	785	1571	2356	3142	3927	4712	5498	6283	7069	7854
	-	73.6	736	1473	2209	2945	3682	4418	5154	5890	6627	7363
125/32	+	122.7	1227	2454	3682	4909	6136	7363	8590	9817	11045	12272
	-	114.7	1147	2294	3440	4587	5734	6881	8027	9174	10321	11468

+ = Outward stroke  
- = Return stroke

**Note!**  
Select a theoretical force 50-100% larger than the force required

**Main data: P1D-LB**

Cylinder designation	Cylinder bore		Piston rod		Piston rod	Cushioning	Connection
	dia. mm	area cm <sup>2</sup>	dia. mm	area cm <sup>2</sup>	thread	length mm	consumption <sup>2)</sup> liter
P1D-LB032••XXXX <sup>1)</sup>	32	8.0	12	1.1	M10x1.25	17	0.105
P1D-LB040••XXXX <sup>1)</sup>	40	12.6	16	2.0	M12x1.25	19	0.162
P1D-LB050••XXXX <sup>1)</sup>	50	19.6	20	3.1	M16x1.5	20	0.253
P1D-LB063••XXXX <sup>1)</sup>	63	31.2	20	3.1	M16x1.5	23	0.414
P1D-LB080••XXXX <sup>1)</sup>	80	50.3	25	4.9	M20x1.5	23	0.669
P1D-LB100••XXXX <sup>1)</sup>	100	78.5	25	4.9	M20x1.5	27	1.043
P1D-LB125••XXXX <sup>1)</sup>	125	122.7	32	8.0	M27x2	30	1.662

**Total mass including moving parts**

Cylinder designation	Total mass (kg) at 0 mm stroke	Total mass (kg) per 10 mm stroke
P1D-LB032••XXXX <sup>1)</sup>	0.55	0.023
P1D-LB040••XXXX <sup>1)</sup>	0.80	0.033
P1D-LB050••XXXX <sup>1)</sup>	1.20	0.048
P1D-LB063••XXXX <sup>1)</sup>	1.73	0.051
P1D-LB080••XXXX <sup>1)</sup>	2.45	0.075
P1D-LB100••XXXX <sup>1)</sup>	4.00	0.084
P1D-LB125••XXXX <sup>1)</sup>	6.87	0.138

**Mass moving parts only (for cushioning calculation)**

Cylinder designation	Mass moving parts (kg)	
	at 0 mm stroke	Supplement per 10 mm stroke
P1D-LB032••XXXX <sup>1)</sup>	0.13	0.009
P1D-LB040••XXXX <sup>1)</sup>	0.24	0.016
P1D-LB050••XXXX <sup>1)</sup>	0.42	0.025
P1D-LB063••XXXX <sup>1)</sup>	0.50	0.025
P1D-LB080••XXXX <sup>1)</sup>	0.90	0.039
P1D-LB100••XXXX <sup>1)</sup>	1.10	0.039
P1D-LB125••XXXX <sup>1)</sup>	2.34	0.063

1) XXXX = stroke

2) Free air consumption per 10 mm stroke for a double stroke at 6 bar



**Dimensions**

**P1D-B Basic**

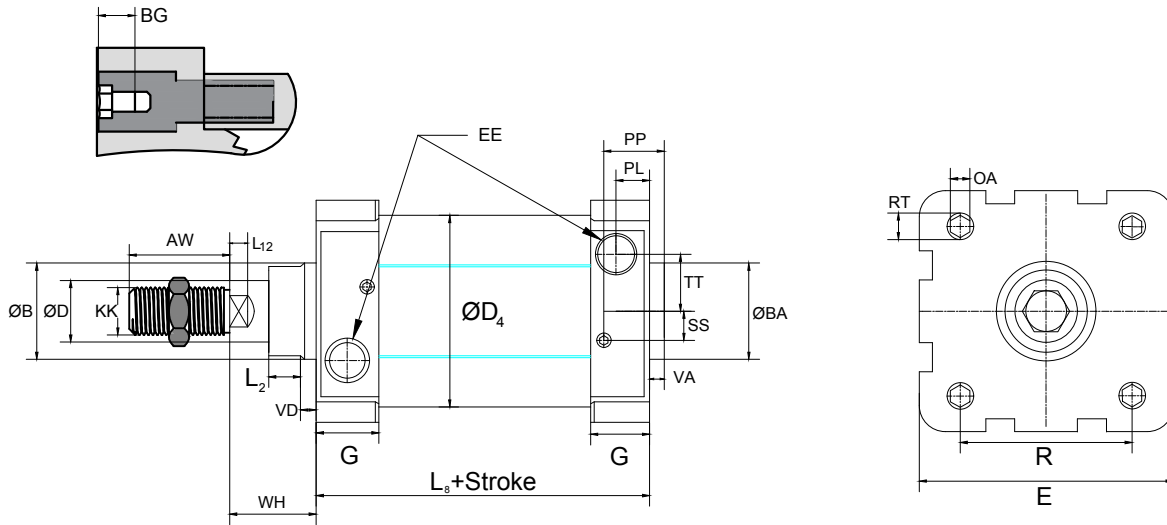

**Dimensions**

Cylinder bore mm	AM mm	B mm	BA mm	BG mm	D mm	D4 mm	E mm	EE		G mm	KK mm	L2 mm	L8 mm
								BSP	BSP				
32	22	30	30	14	12	45.0	45.0	G1/8		26.0	M10x1.25	8.0	94
40	24	35	35	14	16	52.0	54.0	G1/4		29.6	M12x1.25	10.0	105
50	32	40	40	15	20	60.7	64.0	G1/4		30.0	M16x1.5	17.0	106
63	32	45	45	15	20	71.5	75.0	G3/8		35.5	M16x1.5	17.0	121
80	40	45	45	17	25	86.7	93.0	G3/8		36.0	M20x1.5	24.5	128
100	40	55	55	17	25	106.7	110.0	G1/2		39.0	M20x1.5	25.5	138
125	54	60	60	20	32	134.0	134.0	G1/2		44.7	M27x2	33.5	160

\* ISO 1179-1 with ISO 228-1 threads

Cylinder bore mm	L12	OA mm	PL mm	PP mm	R mm	RT	SS mm	SW mm	TT mm	VA mm	VD mm	WH mm
40	6.5	6.0	15.5	23.5	38.0	M6	8.0	13	6.0	4.0	10.0	30
50	8.0	8.0	15.5	23.5	46.5	M8	10	17	8.5	4.0	10.0	37
63	8.0	8.0	20.0	29.5	56.5	M8	12.4	17	10.0	4.0	10.0	37
80	10.0	10.0	19.5	29.5	72.0	M10	12.5	22	8.0	4.0	10.0	46
100	11.0	10.0	20.0	32.0	89.0	M10	11.8	22	10.0	4.0	12.5	51
125	14.0	12.0	30.0	50.0	110.0	M12	13.0	28	8.0	4.0	12.5	65

**Tolerances**

Cylinder bore mm	B	BA	L8 mm	R mm	Stroke tolerance up to stroke 500 mm	Stroke tolerance for stroke over 500 mm
32	d11	d11	±0.4	±0.5	+0.3/+2.0	+0.3/+3.0
40	d11	d11	±0.7	±0.5	+0.3/+2.0	+0.3/+3.0
50	d11	d11	±0.7	±0.6	+0.3/+2.0	+0.3/+3.0
63	d11	d11	±0.8	±0.7	+0.3/+2.0	+0.3/+3.0
80	d11	d11	±0.8	±0.7	+0.3/+2.0	+0.3/+3.0
100	d11	d11	±1.0	±0.7	+0.3/+2.0	+0.3/+3.0
125	d11	d11	±1.0	±1.1	+0.3/+2.0	+0.3/+3.0



**Rod End Dimensions**

**All Mountings Except MF1**

**Thread Style N**

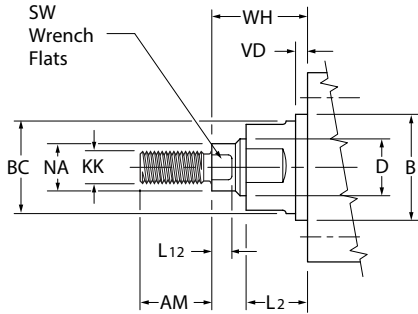

**Thread Style 6**

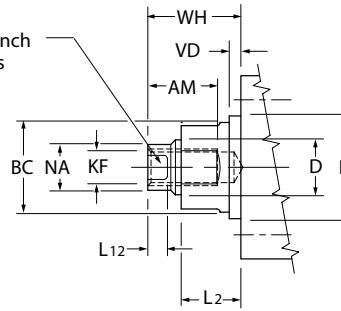

**“Special Thread” Style 3**

Special thread, extension, rod eye, blank, etc are also available. To order, specify “Style 3” and provide desired dimensions for KF or KK, AM and WH. If otherwise special, furnish dimensioned sketch.

Bore	D	KK	KF	AM	B d11	BC	SW across flats	L12	NA	VD	L2	WH*
32	12	M10x1.25	M8x1	22	30	27	10	6	11	4.5	18	26
40	16	M12x1.25	M10x1.25	24	35	32	13	6.5	15	4.5	20	30
50	20	M16x1.5	M14x1.5	32	40	36	17	6.5	19	4.5	26	37
63	20	M16x1.5	M14x1.5	32	45	36	17	6.5	19	4.5	26	37
80	25	M20x1.5	M18x1.5	40	45	41	22	10	24	4.5	33	46
100	25	M20x1.5	M18x1.5	40	55	41	22	10	24	4.5	33	51
125	32	M27x2	M24x2	54	60	50	27	13	31	6.5	41	65

**With MF1 Mounting**

**Thread Style N**

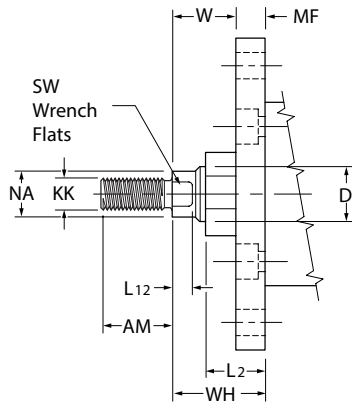

**Thread Style 6**

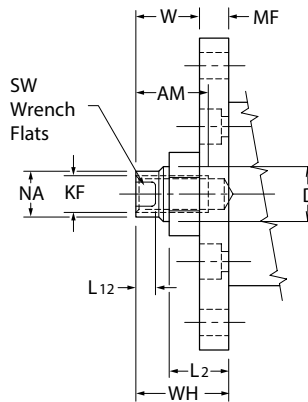

**“Special Thread” Style 3**

Special thread, extension, rod eye, blank, etc are also available. To order, specify “Style 3” and provide desired dimensions for KF or KK, AM and WH. If otherwise special, furnish dimensioned sketch.

Bore	D	KK	KF	AM	SW across flats	L12	MF	NA	L2	W†	WH†
32	12	M10x1.25	M8x1	22	10	6	10	11	18	16	26
40	16	M12x1.25	M10x1.25	24	13	6.5	10	15	20	20	30
50	20	M16x1.5	M14x1.5	32	17	6.5	12	19	26	25	37
63	20	M16x1.5	M14x1.5	32	17	6.5	12	19	26	25	37
80	25	M20x1.5	M18x1.5	40	22	10	16	24	33	30	46
100	25	M20x1.5	M18x1.5	40	22	10	16	24	33	35	51
125	32	M27x2	M24x2	54	27	13	20	31	41	45	65

## Cylinder Mountings

### Flange – MF1, MF2



Intended for fixed mounting of cylinder. Flange can be fitted to front or rear end cover of cylinder.

**Materials:**

32-100mm bore flange: Surface-treated aluminum, black  
 125mm bore flange: Steel, black  
 Mounting screws acc. to DIN 6912: Zinc-plated steel 8.8

Supplied complete with mounting screws for attachment to cylinder.

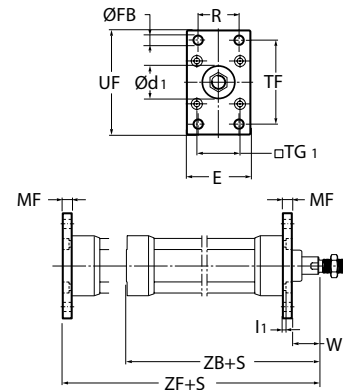

According to ISO MF1/MF2, VDMA 24 562, AFNOR

Bore size mm	d1 H11 mm	FB H13 mm	TG1 mm	E mm	R JS14 mm	MF JS14 mm	TF JS14 mm	UF	I1 -0.5 mm	W mm	ZF mm	ZB mm	Weight kg	Part number
32	30	7	32.5	45	32	10	64	80	5.0	16	130	123.5	0.23	<b>P1C-4KMBA</b>
40	35	9	38.0	52	36	10	72	90	5.0	20	145	138.5	0.28	<b>P1C-4LMBA</b>
50	40	9	46.5	65	45	12	90	110	6.5	25	155	146.5	0.53	<b>P1C-4MMBA</b>
63	45	9	56.5	75	50	12	100	120	6.5	25	170	161.5	0.71	<b>P1C-4NMBA</b>
80	45	12	72.0	95	63	16	126	150	8.0	30	190	177.5	1.59	<b>P1C-4PMBA</b>
100	55	14	89.0	112	75	16	150	185	8.0	35	205	192.5	2.19	<b>P1C-4QMBA</b>
125	60	16	110.0	140	90	20	180	220	10.5	45	245	230.5	3.78	<b>P1C-4RMB</b>

S = Stroke length

### Foot Bracket – MS1



Intended for fixed mounting of cylinder. Foot bracket can be fitted to front and rear end covers of cylinder.

**Materials:**

Foot bracket: Surface-treated steel, black  
 Mounting screws acc. to DIN 912: Zinc-plated steel 8.8

Supplied in pairs with mounting screws for attachment to cylinder.

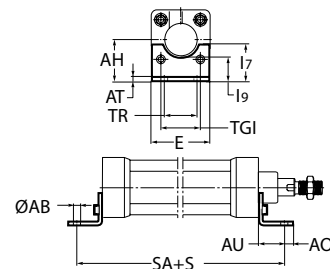

According to ISO MS1, VDMA 24 562, AFNOR

Bore size mm	AB H14 mm	TG1 mm	E mm	TR JS14 mm	AO mm	AU mm	AH JS15 mm	l7 mm	AT mm	l9 JS14 mm	SA mm	Weight* kg	Part number
32	7	32.5	45	32	10	24	32	30	4.5	17.0	142	0.06	<b>P1C-4KMF</b>
40	9	38.0	52	36	8	28	36	30	4.5	18.5	161	0.08	<b>P1C-4LMF</b>
50	9	46.5	65	45	13	32	45	36	5.5	25.0	170	0.16	<b>P1C-4MMF</b>
63	9	56.5	75	50	13	32	50	35	5.5	27.5	185	0.25	<b>P1C-4NMF</b>
80	12	72.0	95	63	14	41	63	49	6.5	40.5	210	0.50	<b>P1C-4PMF</b>
100	14	89.0	115	75	15	41	71	54	6.5	43.5	220	0.85	<b>P1C-4QMF</b>
125	16	110.0	140	90	22	45	90	71	8.0	60.0	250	1.48	<b>P1C-4RMF</b>

S = Stroke length

\*Weight per item



## Cylinder Mountings

### Pivot Bracket with Rigid Bearing



Intended for flexible mounting of cylinder. The pivot bracket can be combined with clevis bracket MP2.

**Materials:**

Pivot bracket: Surface-treated aluminium, black  
 Bearing: Sintered oil-bronze bushing

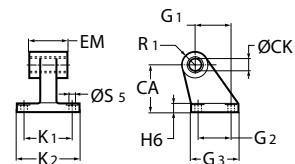

According to CETOP RP 107 P, VDMA 24 562, AFNOR

Bore size mm	CK H9 mm	S5 H13 mm	K1 JS14 mm	K2	G1 JS14 mm	G2 JS14 mm	EM mm	G3 mm	CA JS15 mm	H6 mm	R1 mm	Weight kg	Part number
32	10	6.6	38	51	21	18	25.5	31	32	8	10.0	0.06	<b>P1C-4KMD</b>
40	12	6.6	41	54	24	22	27.0	35	36	10	11.0	0.08	<b>P1C-4LMD</b>
50	12	9.0	50	65	33	30	31.0	45	45	12	13.0	0.15	<b>P1C-4MMD</b>
63	16	9.0	52	67	37	35	39.0	50	50	12	15.0	0.20	<b>P1C-4NMD</b>
80	16	11.0	66	86	47	40	49.0	60	63	14	15.0	0.33	<b>P1C-4PMD</b>
100	20	11.0	76	96	55	50	59.0	70	71	15	19.0	0.49	<b>P1C-4QMD</b>
125	25	14.0	94	124	70	60	69.0	90	90	20	22.5	1.02	<b>P1C-4RMD</b>

### Swivel Eye Bracket – MP6



Intended for use together with clevis bracket GA

**Materials:**

Bracket: Surface-treated aluminium, black  
 Swivel bearing acc. to DIN 648K: Hardened steel  
 Supplied complete with mounting screws for attachment to cylinder.

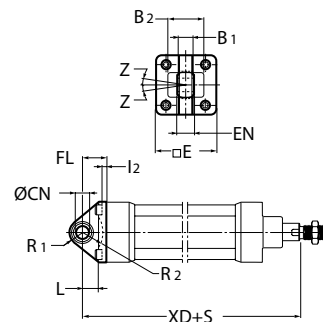

According to VDMA 24 562, AFNOR

Bore size mm	E mm	B1 mm	B2 mm	EN mm	R1 mm	R2 mm	FL mm	I2 mm	L mm	CN H7 mm	XD mm	Z	Weight kg	Part number
32	45	10.5	–	14	16	–	22	5.5	12	10	142	4°	0.08	<b>P1C-4KMSA</b>
40	52	12.0	–	16	18	–	25	5.5	15	12	160	4°	0.11	<b>P1C-4LMSA</b>
50	65	15.0	51	21	21	19	27	6.5	15	16	170	4°	0.20	<b>P1C-4MMSA</b>
63	75	15.0	–	21	23	–	32	6.5	20	16	190	4°	0.27	<b>P1C-4NMSA</b>
80	95	18.0	–	25	29	–	36	10.0	20	20	210	4°	0.52	<b>P1C-4PMSA</b>
100	115	18.0	–	25	31	–	41	10.0	25	20	230	4°	0.72	<b>P1C-4QMSA</b>
125	140	25.0	–	37	40	–	50	10.0	30	30	275	4°	1.53	<b>P1C-4RMSA</b>

S = Stroke length

## Cylinder Mountings

### Clevis Bracket – MP2



Intended for flexible mounting of cylinder. Clevis bracket MP2 can be combined with clevis bracket MP4.

**Materials:**

Clevis bracket: Surface-treated aluminium, black for 32-125mm bores;

Pin: Surface hardened steel

Circlips according to DIN 471: Spring steel

Mounting screws acc. to DIN 912: Zinc-plated steel 8.8

Supplied complete with mounting screws for attachment to cylinder.

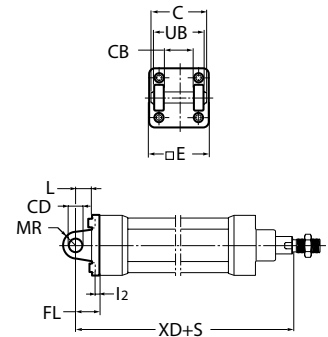

According to ISO MP2, VDMA 24 562, AFNOR

Bore size mm	C mm	E mm	UB h14 mm	CB H14 mm	FL ±0.2 mm	L mm	l2 mm	CD H9 mm	MR mm	XD mm	Weight kg	Part number
32	53	45	45	26	22	13	5.5	10	10	142	0.08	P1C-4KMT
40	60	52	52	28	25	16	5.5	12	12	160	0.11	P1C-4LMT
50	68	65	60	32	27	16	6.5	12	12	170	0.14	P1C-4MMT
63	78	75	70	40	32	21	6.5	16	16	190	0.29	P1C-4NMT
80	98	95	90	50	36	22	10.0	16	16	210	0.36	P1C-4PMT
100	118	115	110	60	41	27	10.0	20	20	230	0.64	P1C-4QMT
125	139	140	130	70	50	30	10.0	25	25	275	1.17	P1C-4RMT

S = Stroke length

### Clevis Bracket – MP4



Intended for flexible mounting of cylinder. Clevis bracket MP4 can be combined with clevis bracket MP2.

**Materials:**

Clevis bracket: Surface-treated aluminium, black for 32-125mm bores

Mounting screws acc. to DIN 912: Zinc-plated steel 8.8

Supplied complete with mounting screws for attachment to cylinder.

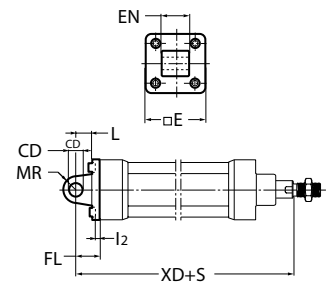

According to ISO MP4, VDMA 24 562, AFNOR

Bore size mm	E mm	EW mm	FL mm	L ±0.2 mm	l2 mm	CD mm	MR H9 mm	XD mm	Weight kg	Part number
32	45	26	22	13	5.5	10	10	142	0.09	P1C-4KME
40	52	28	25	16	5.5	12	12	160	0.13	P1C-4LME
50	65	32	27	16	6.5	12	12	170	0.17	P1C-4MME
63	75	40	32	21	6.5	16	16	190	0.36	P1C-4NME
80	95	50	36	22	10.0	16	16	210	0.46	P1C-4PME
100	115	60	41	27	10.0	20	20	230	0.83	P1C-4QME
125	140	70	50	30	10.0	25	25	275	1.53	P1C-4RME

S = Stroke length

**Cylinder Mountings**

**Mounting Kit**



Mounting kit for back to back mounted cylinders, 3 and 4 position duplex cylinders.

**Materials:**

Mounting: Aluminium  
Mounting screws: Zinc-plated steel 8.8

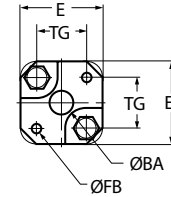
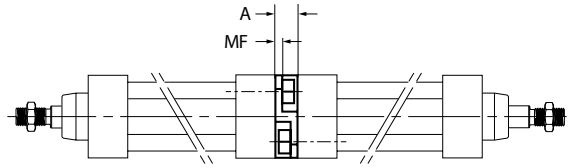

Bore size mm	E mm	TG mm	ØFB mm	MF mm	A mm	ØBA mm	Weight kg	Part number
32	50	32.5	6.5	5	16	30	0.060	<b>P1E-6KB0</b>
40	60	38.0	6.5	5	16	35	0.078	<b>P1E-6LB0</b>
50	66	46.5	8.5	6	20	40	0.162	<b>P1E-6MB0</b>
63	80	56.5	8.5	6	20	45	0.194	<b>P1E-6NB0</b>
80	100	72.0	10.5	8	25	45	0.450	<b>P1E-6PB0</b>
100	118	89.0	10.5	8	25	55	0.672	<b>P1E-6QB0</b>

**Pivot Bracket – MT4**



Intended for use together with central trunnion MT4.

**Materials:**

Pivot bracket: Surface-treated aluminium  
Bearing acc. to DIN 1850 C: Sintered oil-bronze bushing  
Supplied in pairs.

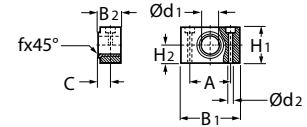

According to ISO, VDMA 24 562, AFNOR

Bore size mm	B1 mm	B2 mm	A mm	C mm	d1 mm	d2 H13 mm	H1 mm	H2 mm	fx45° min mm	Weight* kg	Part number
32	46	18.0	32	10.5	12	6.6	30	15	1.0	0.04	<b>9301054261</b>
40	55	21.0	36	12.0	16	9.0	36	18	1.6	0.07	<b>9301054262</b>
50	55	21.0	36	12.0	16	9.0	36	18	1.6	0.07	<b>9301054262</b>
63	65	23.0	42	13.0	20	11.0	40	20	1.6	0.12	<b>9301054264</b>
80	65	23.0	42	13.0	20	11.0	40	20	1.6	0.12	<b>9301054264</b>
100	75	28.5	50	16.0	25	14.0	50	25	2.0	0.21	<b>9301054266</b>
125	75	28.5	50	16.0	25	14.0	50	25	2.0	0.21	<b>9301054266</b>

\* Weight per item

## Cylinder Mountings

### Intermediate Trunnion – MT4



Standard\*

Intended for articulated mounting of cylinder. The trunnion is factory-fitted at an optional location. Order by specifying Mounting Style G or 7 and providing the desired XV dimension (3-digit measure in mm). See page 3 for ordering information. Combined with pivot bracket for MT4 for 32-125mm bores.

**Materials:**

Trunnion: Zinc plated steel

\* Standard mounting is for the Standard cylinder body and is permanently affixed by the factory.

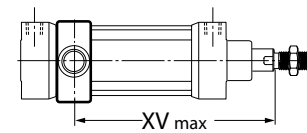
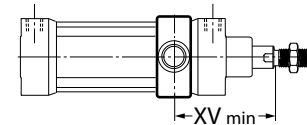
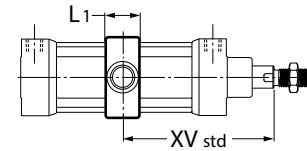
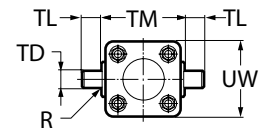

According to ISO MT4, VDMA 24 562, AFNOR

Bore size mm	TM h14 mm	TL h14 mm	TD e9 mm	R mm	UW mm	L1 mm	X1 mm	XVmin mm	X2 mm	Weight kg
32	50	12	12	1.0	46	15	73.0	70.0	84.0	0.13
40	63	16	16	1.6	59	20	82.5	83.0	92.0	0.31
50	75	16	16	1.6	69	20	90.0	90.5	99.5	0.37
63	90	20	20	1.6	84	25	97.5	101.5	106.0	0.69
80	110	20	20	1.6	102	25	110.0	110.5	122.0	0.89
100	132	25	25	2.0	125	30	120.0	125.5	129.5	1.58
125	160	25	25	2.0	155	32	145.0	148.0	158.0	2.60

$XV_{std} = X1 + \text{Stroke length}/2$       $XV_{max} = X2 + \text{Stroke length}$

### Flange Mounted Trunnion



Intended for articulated mounting of cylinder. This trunnion can be flange mounted on the front or rear end cover of all P1D cylinders. If you choose, you can order a complete cylinder with factory-fitted flange mounted trunnion – see the ordering information on page 3 Individual trunnions have part numbers as shown below.

**Materials:**

Trunnion: zinc plated steel

Screws: zinc plated steel, 8.8

Delivered complete with mounting screws for attachment to the cylinder

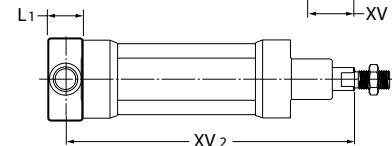
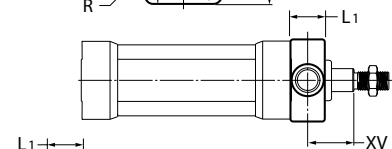
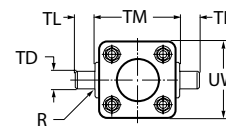

According to ISO MT4, VDMA 24 562, AFNOR

Bore size mm	TM h14 mm	TL h14 mm	TD e9 mm	R mm	UW mm	L1 mm	XV <sub>1</sub> mm	X mm	Weight kg	Part number
32	50	12	12	1.0	46	14	19.0	127.0	0.17	<b>P1D-4KMYF</b>
40	63	16	16	1.6	59	19	20.5	144.5	0.43	<b>P1D-4LMYF</b>
50	75	16	16	1.6	69	19	27.5	152.5	0.55	<b>P1D-4MMYF</b>
63	90	20	20	1.6	84	24	25.0	170.0	1.10	<b>P1D-4NMYF</b>
80	110	20	20	1.6	102	24	34.0	186.0	1.66	<b>P1D-4PMYF</b>
100	132	25	25	2.0	155	29	36.5	203.5	3.00	<b>P1D-4QMYF</b>

$XV_2 = X + \text{Stroke length}$



## Cylinder Mountings

### Intermediate Trunnion – MT4



Standard\*

Intended for articulated mounting of cylinder. The trunnion is factory-fitted at an optional location. Order by specifying Mounting Style G or 7 and providing the desired XV dimension (3-digit measure in mm). See page 3 for ordering information. Combined with pivot bracket for MT4 for 32-125mm bores.

**Materials:**

Trunnion: Zinc plated steel

\* Standard mounting is for the Standard cylinder body and is permanently affixed by the factory.

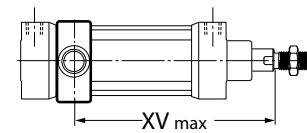
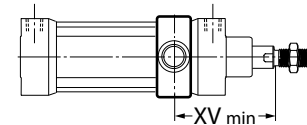
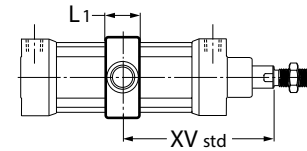
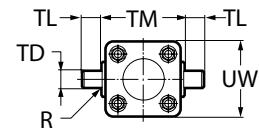

According to ISO MT4, VDMA 24 562, AFNOR

Bore size mm	TM h14 mm	TL h14 mm	TD e9 mm	R mm	UW mm	L1 mm	X1 mm	XVmin mm	X2 mm	Weight kg
32	50	12	12	1.0	46	15	73.0	70.0	84.0	0.13
40	63	16	16	1.6	59	20	82.5	83.0	92.0	0.31
50	75	16	16	1.6	69	20	90.0	90.5	99.5	0.37
63	90	20	20	1.6	84	25	97.5	101.5	106.0	0.69
80	110	20	20	1.6	102	25	110.0	110.5	122.0	0.89
100	132	25	25	2.0	125	30	120.0	125.5	129.5	1.58
125	160	25	25	2.0	155	32	145.0	148.0	158.0	2.60

$XV_{std} = X1 + \text{Stroke length}/2$       $XV_{max} = X2 + \text{Stroke length}$

### Flange Mounted Trunnion



Intended for articulated mounting of cylinder. This trunnion can be flange mounted on the front or rear end cover of all P1D cylinders. If you choose, you can order a complete cylinder with factory-fitted flange mounted trunnion – see the ordering information on page 3 Individual trunnions have part numbers as shown below.

**Materials:**

Trunnion: zinc plated steel

Screws: zinc plated steel, 8.8

Delivered complete with mounting screws for attachment to the cylinder

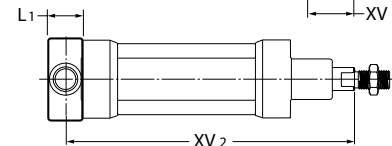
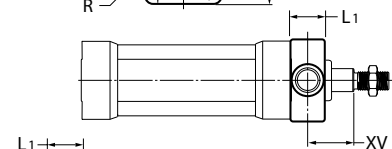
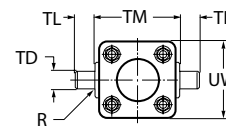

According to ISO MT4, VDMA 24 562, AFNOR

Bore size mm	TM h14 mm	TL h14 mm	TD e9 mm	R mm	UW mm	L1 mm	XV <sub>1</sub> mm	X mm	Weight kg	Part number
32	50	12	12	1.0	46	14	19.0	127.0	0.17	<b>P1D-4KMYF</b>
40	63	16	16	1.6	59	19	20.5	144.5	0.43	<b>P1D-4LMYF</b>
50	75	16	16	1.6	69	19	27.5	152.5	0.55	<b>P1D-4MMYF</b>
63	90	20	20	1.6	84	24	25.0	170.0	1.10	<b>P1D-4NMYF</b>
80	110	20	20	1.6	102	24	34.0	186.0	1.66	<b>P1D-4PMYF</b>
100	132	25	25	2.0	155	29	36.5	203.5	3.00	<b>P1D-4QMYF</b>

$XV_2 = X + \text{Stroke length}$



## Cylinder Mountings

### Swivel Rod Eye



**Stainless Steel Swivel Rod Eye**

Swivel rod eye for articulated mounting of cylinder.  
Swivel rod eye can be combined with clevis bracket GA.  
Maintenance-free.

**Materials:**

Swivel rod eye: Zinc-plated steel  
Swivel bearing according to DIN 648K: Hardened steel

Swivel rod eye: Stainless steel  
Swivel bearing according to DIN 648K: Stainless steel

Use stainless steel nut (see next page) with stainless steel swivel rod eye.

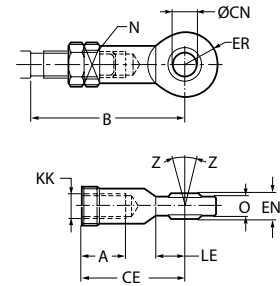

According to ISO 8139

Bore size mm	A mm	B min mm	B max mm	CE mm	CN H9 mm	EN h12 mm	ER mm	KK	LE min mm	N mm	O mm	Z	Weight kg	Part number	Stainless steel part number
32	20	48.0	55	43	10	14	14	M10x1.25	15	17	10.5	12°	0.08	<b>P1C-4KRS</b>	<b>P1S-4JRT</b>
40	22	56.0	62	50	12	16	16	M12x1.25	17	19	12.0	12°	0.12	<b>P1C-4LRS</b>	<b>P1S-4LRT</b>
50	28	72.0	80	64	16	21	21	M16x1.5	22	22	15.0	15°	0.25	<b>P1C-4MRS</b>	<b>P1S-4MRT</b>
63	28	72.0	80	64	16	21	21	M16x1.5	22	22	15.0	15°	0.25	<b>P1C-4PRS</b>	<b>P1S-4PRT</b>
80	33	87.0	97	77	20	25	25	M20x1.5	26	32	18.0	15°	0.46	<b>P1C-4RRS</b>	<b>P1S-4RRT</b>
100	33	87.0	97	77	20	25	25	M20x1.5	26	32	18.0	15°	0.46	<b>P1C-4RRS</b>	<b>P1S-4RRT</b>
125	51	123.5	137	110	30	37	35	M27x2	36	41	25.0	15°	1.28	<b>P1C-4RRS</b>	<b>P1S-4RRT</b>

### Clevis



**Stainless Steel Clevis**

Clevis for articulated mounting of cylinder.

**Materials:**

Clevis, clip: Galvanized steel  
Pin: Hardened steel

Clevis: Stainless steel  
Pin: Stainless steel  
Circlips according to DIN 471: Stainless steel

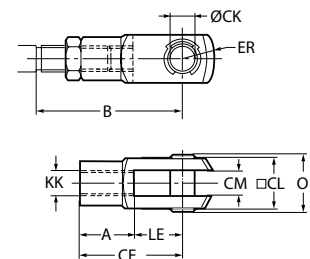

According to ISO 8140

Bore size mm	A mm	B min mm	B max mm	CE mm	CK h11/E9 mm	CL mm	CM mm	ER mm	KK	LE mm	O mm	Weight kg	Part number	Stainless steel part number
32	20	45.0	52	40	10	20	10	16	M10x1.25	20	28.0	0.09	<b>P1C-4KRC</b>	<b>P1S-4JRD</b>
40	24	54.0	60	48	12	24	12	19	M12x1.25	24	32.0	0.15	<b>P1C-4LRC</b>	<b>P1S-4LRD</b>
50	32	72.0	80	64	16	32	16	25	M16x1.5	32	41.5	0.35	<b>P1C-4MRC</b>	<b>P1S-4MRD</b>
63	32	72.0	80	64	16	32	16	25	M16x1.5	32	41.5	0.35	<b>P1C-4MRC</b>	<b>P1S-4MRD</b>
80	40	90.0	100	80	20	40	20	32	M20x1.5	40	50.0	0.75	<b>P1C-4PRC</b>	<b>P1S-4PRD</b>
100	40	90.0	100	80	20	40	20	32	M20x1.5	40	50.0	0.75	<b>P1C-4PRC</b>	<b>P1S-4PRD</b>
125	56	123.5	137	110	30	55	30	45	M27x2	54	72.0	2.10	<b>P1C-4RRC</b>	<b>P1S-4RRD</b>

**Cylinder Mountings**



Flexo coupling for articulated mounting of piston rod. Flexo fitting is intended to take up axial angle errors within a range of  $\pm 4^\circ$ .

**Materials:**

Flexo coupling, nut: Zinc-plated steel  
 Socket: Hardened steel

Supplied complete with galvanized adjustment nut.

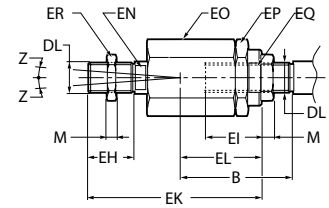

Bore size mm	B min mm	B max mm	DL	EH mm	EI mm	EK mm	EL mm	EN mm	EO mm	EP mm	EQ mm	ER mm	M mm	Z	Weight kg	Part number
32	36.0	43	M10x1.25	20	23	70	31	12	30	30	19	30	5.0	4°	0.21	<b>P1C-4KRF</b>
40	37.0	43	M12x1.25	23	23	67	31	12	30	30	19	30	6.0	4°	0.22	<b>P1C-4LRF</b>
50	53.0	61	M16x1.5	40	32	112	45	19	41	41	30	41	8.0	4°	0.67	<b>P1C-4MRF</b>
63	53.0	61	M16x1.5	40	32	112	45	19	41	41	30	41	8.0	4°	0.67	
80	57.0	67	M20x1.5	39	42	122	56	19	41	41	30	41	10.0	4°	0.72	<b>P1C-4PRF</b>
100	57.0	67	M20x1.5	39	42	122	56	19	41	41	30	41	10.0	4°	0.72	
125	75.5	89	M27x2	48	48	145	60	24	55	55	32	55	13.5	4°	1.80	<b>P1C-4RRF</b>

**Nuts**



Intended for fixed mounting of accessories to the piston rod.

**Materials:**

Zinc plated steel

All P1D-B cylinders are delivered with a zinc-plated steel piston rod nut.

**Stainless Steel Nut**

**Material:**

Stainless steel A2

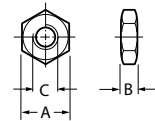

**According to DIN 439 B**

Bore size mm	A mm	B mm	C	Weight kg	Part numbers	
					Steel	Stainless steel
32	17	5.0	M10x1.25	0.007	<b>9128985601</b>	<b>9126725404</b>
40	19	6.0	M12x1.25	0.010	<b>0261109910</b>	<b>9126725405</b>
50	24	8.0	M16x1.5	0.021	<b>9128985603</b>	<b>9126725406</b>
63	24	8.0	M16x1.5	0.021		
80	30	10.0	M20x1.5	0.040	<b>0261109911</b>	<b>0261109921</b>
100	30	10.0	M20x1.5	0.040		
125	41	13.5	M27x2	0.100	<b>0261109912</b>	<b>0261109922</b>

## Sensors

### New drop-in sensors

The P1D sensors can easily be installed from the side in the sensor groove, at any position along the piston stroke.

The sensors are completely recessed and thus mechanically protected. Choose between electronic or reed sensors and several cable lengths and 8 mm and M12 connectors.

The same standard sensors are used for all P1D versions.



### Electronic sensors

The new electronic sensors are “Solid State”, i.e. they have no moving parts at all. They are provided with short-circuit protection and transient protection as standard. The built-in electronics make the sensors suitable for applications with high on and off switching frequency, and where very long service life is required.

#### Technical data

<b>Design</b>	GMR (Giant Magnetic Resistance) magneto-resistive function
<b>Installation</b>	From side, down into the sensor groove, so-called drop-in
<b>Outputs</b>	PNP, normally open (also available in NPN design, normally closed, on request)
<b>Voltage range</b>	10-30 VDC
<b>Ripple</b>	max 10%
<b>Voltage drop</b>	max 2.5 V
<b>Load current</b>	max 100 mA
<b>Internal consumption</b>	max 10 mA
<b>Actuating distance</b>	min 9 mm
<b>Hysteresis</b>	max 1.5 mm
<b>Repeatability accuracy</b>	max 0.2 mm
<b>On/off switching frequency</b>	max 5 kHz
<b>On switching time</b>	max 2 ms
<b>Off switching time</b>	max 2 ms
<b>Encapsulation</b>	IP 67 (EN 60529)
<b>Temperature range</b>	-25°C to +75°C
<b>Indication</b>	LED, yellow
<b>Material housing</b>	PA 12
<b>Material screw</b>	Stainless steel
<b>Cable</b>	PVC or PUR 3x0.25 mm <sup>2</sup> see order code respectively

### Reed sensors

The sensors are based on proven reed switches, which offer reliable function in many applications. Simple installation, a protected position on the cylinder and clear LED indication are important advantages of this range of sensors.

#### Technical data

<b>Design</b>	Reed element
<b>Mounting</b>	From side, down into the sensor groove, so-called drop-in
<b>Output</b>	Normally open, or normally closed
<b>Voltage range</b>	10-30 VDC or 10-120 VAC
<b>Load current</b>	max 500 mA for 10-30 V or max 100 mA for 10-120 V
<b>Breaking power (resistive)</b>	max 6 W/VA
<b>Actuating distance</b>	min 9 mm
<b>Hysteresis</b>	max 1.5 mm
<b>Repeatability accuracy</b>	0.2 mm
<b>On/off switching frequency</b>	max 400 Hz
<b>On switching time</b>	max 1.5 ms
<b>Off switching time</b>	max 0.5 ms
<b>Encapsulation</b>	IP 67 (EN 60529)
<b>Temperature range</b>	-25°C to +75°C
<b>Indication</b>	LED, yellow
<b>Material housing</b>	PA12
<b>Material screw</b>	Stainless steel
<b>Cable</b>	PVC or PUR 3x0.14 mm <sup>2</sup> see order code respectively



**Sensors**

**Ordering data**

Output / function	Cable / connector	Weight (kg)	Part number
<b>Electronic sensors, 10-30 VDC</b>			
PNP type, normally open	0.27 m PUR-cable and 8 mm snap-in male connector	0.007	<b>P8S-GPSHX</b>
PNP type, normally open	0.27 m PUR-cable and M12 screw male connector	0.015	<b>P8S-GPMHX</b>
PNP type, normally open	3 m PVC-cable without connector	0.030	<b>P8S-GPFLX</b>
PNP type, normally open	10 m PVC-cable without connector	0.110	<b>P8S-GPFTX</b>
<b>Reed sensors, 10-30 VDC / 10-120 VAC</b>			
Normally open	0.27 m PUR-cable and 8 mm snap-in male connector	0.007	<b>P8S-GRSHX</b>
Normally open	0.27 m PUR-cable and M12 screw male connector	0.015	<b>P8S-GRMHX</b>
Normally open	3 m PVC-cable without connector	0.030	<b>P8S-GRFLX</b>
Normally open	10 m PVC-cable without connector	0.110	<b>P8S-GRFTX</b>

**Note:** For NPN sensors, see catalog PDN1000US-2

**Electronic sensors**

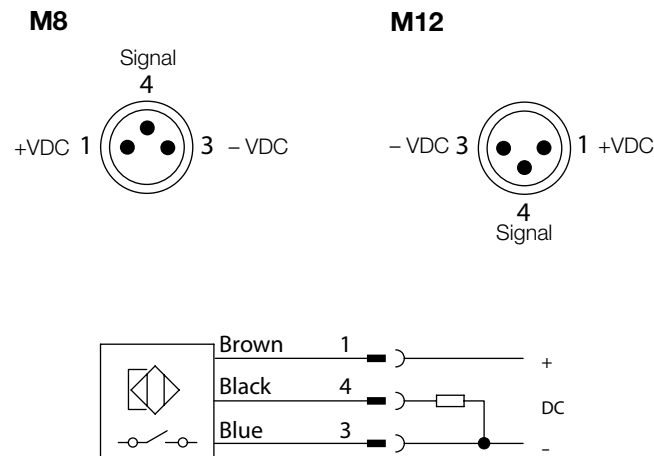

**Reed sensors**

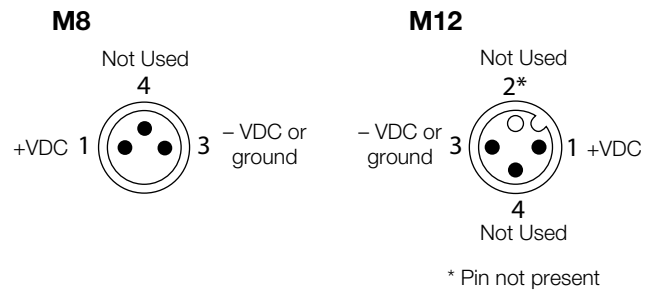

**Dimensions**

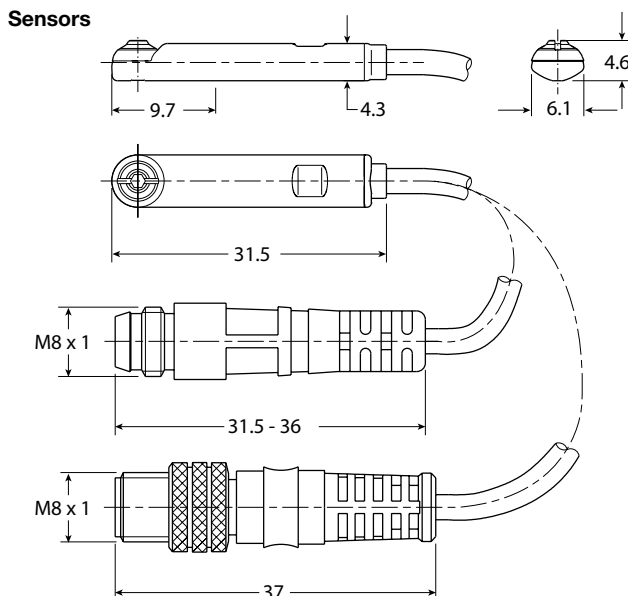

**Sensor Installation**

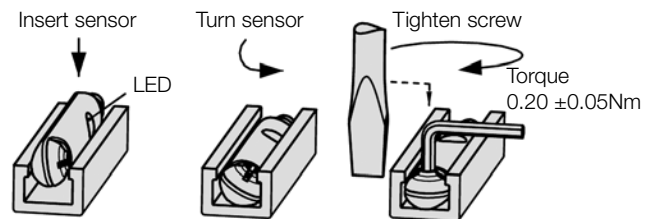

**P1D-LB Seal Kits**

**Order codes**

Cylinder bore mm	P1D cylinder version Standard P1D-LB
32	<b>P1D-6KRN</b>
40	<b>P1D-6LRN</b>
50	<b>P1D-6MRN</b>
63	<b>P1D-6NRN</b>
80	<b>P1D-6PRN</b>
100	<b>P1D-6QRN</b>
125	<b>P1D-6RRN</b>

**Grease**



**STANDARD 5301110634**

**Seal kit**

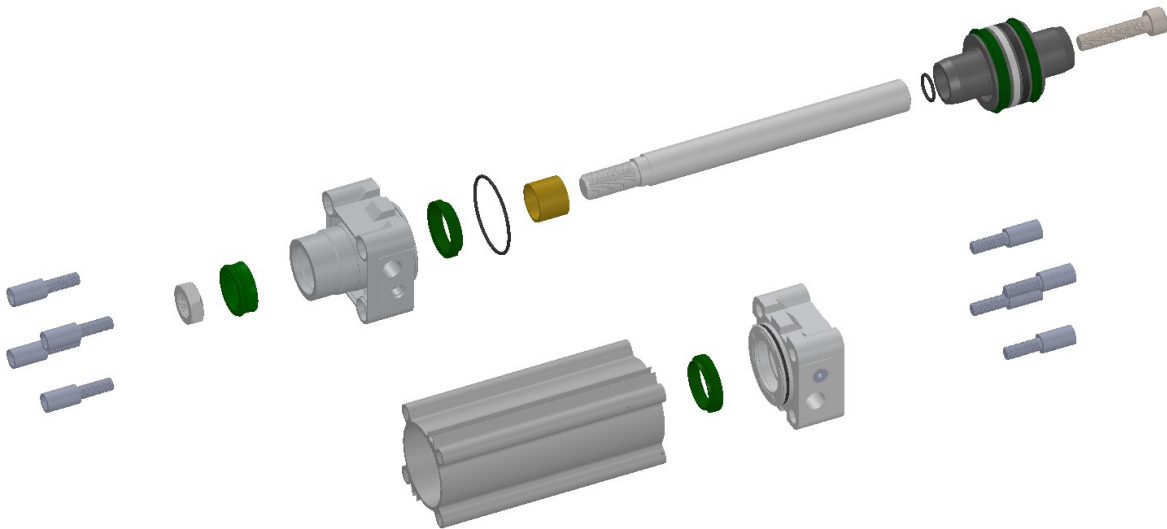

= Included in seal kit



= Lubricated with grease



= Socket head



= Locking fluid



= Tightening torque

*Loctite 270 or Loctite 2701 locking fluid must be used*

Cylinder dia. mm	Plastic piston T1 Nm	NV mm	T2 Nm	NV mm
32	4.5	6	8	6
40	11	8	8	6
50	20	10	20	8
63	20	10	20	8
80	40	14	20	6
100	120	14	20	6
125	120	14	70	8

## Safety Guide

### Safety Guide for Selecting and Using Hydraulic, Pneumatic Cylinders and Their Accessories

**WARNING: ⚠ FAILURE OF THE CYLINDER, ITS PARTS, ITS MOUNTING, ITS CONNECTIONS TO OTHER OBJECTS, OR ITS CONTROLS CAN RESULT IN:**

- Unanticipated or uncontrolled movement of the cylinder or objects connected to it.
- Falling of the cylinder or objects held up by it.
- Fluid escaping from the cylinder, potentially at high velocity.

**THESE EVENTS COULD CAUSE DEATH OR PERSONAL INJURY BY, FOR EXAMPLE, PERSONS FALLING FROM HIGH LOCATIONS, BEING CRUSHED OR STRUCK BY HEAVY OR FAST MOVING OBJECTS, BEING PUSHED INTO DANGEROUS EQUIPMENT OR SITUATIONS, OR SLIPPING ON ESCAPED FLUID.**

Before selecting or using Parker (The Company) cylinders or related accessories, it is important that you read, understand and follow the following safety information. Training is advised before selecting and using The Company's products.

#### 1.0 General Instructions

**1.1 Scope** – This safety guide provides instructions for selecting and using (including assembling, installing, and maintaining) cylinder products. This safety guide is a supplement to and is to be used with the specific Company publications for the specific cylinder products that are being considered for use.

**1.2 Fail Safe** – Cylinder products can and do fail without warning for many reasons. All systems and equipment should be designed in a fail-safe mode so that if the failure of a cylinder product occurs people and property won't be endangered.

**1.3 Distribution** – Provide a free copy of this safety guide to each person responsible for selecting or using cylinder products. Do not select or use The Company's cylinders without thoroughly reading and understanding this safety guide as well as the specific Company publications for the products considered or selected.

**1.4 User Responsibility** – Due to very wide variety of cylinder applications and cylinder operating conditions, The Company does not warrant that any particular cylinder is suitable for any specific application. This safety guide does not analyze all technical parameters that must be considered in selecting a product. The hydraulic and pneumatic cylinders outlined in this catalog are designed to The Company's design guidelines and do not necessarily meet the design guideline of other agencies such as American Bureau of Shipping, ASME Pressure Vessel Code etc. The user, through its own analysis and testing, is solely responsible for:

- Making the final selection of the cylinders and related accessories.
- Determining if the cylinders are required to meet specific design requirements as required by the Agency(s) or industry standards covering the design of the user's equipment.
- Assuring that the user's requirements are met, OSHA requirements are met, and safety guidelines from the applicable agencies such as but not limited to ANSI are followed and that the use presents no health or safety hazards.
- Providing all appropriate health and safety warnings on the equipment on which the cylinders are used.

**1.5 Additional Questions** – Call the appropriate Company technical service department if you have any questions or require any additional information. See the Company publication for the product being considered or used, or call 1-800-CPARKER, or go to [www.parker.com](http://www.parker.com), for telephone numbers of the appropriate technical service department.

#### 2.0 Cylinder and Accessories Selection

**2.1 Seals** – Part of the process of selecting a cylinder is the selection of seal compounds. Before making this selection, consult the "seal information page(s)" of the publication for the series of cylinders of interest.

The application of cylinders may allow fluids such as cutting fluids, wash down fluids etc. to come in contact with the external area of the cylinder. These fluids may attack the piston rod wiper and or the primary seal and must be taken into account when selecting and specifying seal compounds.

Dynamic seals will wear. The rate of wear will depend on many operating factors. Wear can be rapid if a cylinder is mis-aligned or if the cylinder has been improperly serviced. The user must take seal wear into consideration in the application of cylinders.

**2.2 Piston Rods** – Possible consequences of piston rod failure or separation of the piston rod from the piston include, but are not limited to are:

- Piston rod and or attached load thrown off at high speed.
- High velocity fluid discharge.
- Piston rod extending when pressure is applied in the piston retract mode.

Piston rods or machine members attached to the piston rod may move suddenly and without warning as a consequence of other conditions occurring to the machine such as, but not limited to:

- Unexpected detachment of the machine member from the piston rod.
- Failure of the pressurized fluid delivery system (hoses, fittings, valves, pumps, compressors) which maintain cylinder position.
- Catastrophic cylinder seal failure leading to sudden loss of pressurized fluid.
- Failure of the machine control system.

Follow the recommendations of the "Piston Rod Selection Chart and Data" in the publication for the series of cylinders of interest. The suggested piston rod diameter in these charts must be followed in order to avoid piston rod buckling.

Piston rods are not normally designed to absorb bending moments or loads which are perpendicular to the axis of piston rod motion. These additional loads can cause the piston rod to fail. If these types of additional loads are expected to be imposed on the piston rod, their magnitude should be made known to our engineering department.

The cylinder user should always make sure that the piston rod is securely attached to the machine member.

On occasion cylinders are ordered with double rods (a piston rod extended from both ends of the cylinder). In some cases a stop is threaded on to one of the piston rods and used as an external stroke adjuster. On occasions spacers are attached to the machine member connected to the piston rod and also used as a stroke adjuster. In both cases the stops will create a pinch point and the user should consider appropriate use of guards. If these external stops are not perpendicular to the mating contact surface, or if debris is trapped between the contact surfaces, a bending moment will be placed on the piston rod, which can lead to piston rod failure. An external stop will also negate the effect of cushioning and will subject the piston rod to impact loading. Those two (2) conditions can cause piston rod failure. Internal stroke adjusters are available with and without cushions. The use of external stroke adjusters should be reviewed with our engineering department.

The piston rod to piston and the stud to piston rod threaded connections are secured with an anaerobic adhesive. The strength of the adhesive decreases with increasing temperature. Cylinders which can be exposed to temperatures above +250°F (+121°C) are to be ordered with a non studded piston rod and a pinned piston to rod joint.

**2.3 Cushions** – Cushions should be considered for cylinder applications when the piston velocity is expected to be over 4 inches/second.

Cylinder cushions are normally designed to absorb the energy of a linear applied load. A rotating mass has considerably more energy than the same mass moving in a linear mode. Cushioning for a rotating mass application should be review by our engineering department.

**2.4 Cylinder Mountings** – Some cylinder mounting configurations may have certain limitations such as but not limited to minimum stroke for side or foot mounting cylinders or pressure de-ratings for certain mounts. Carefully review the catalog for these types of restrictions.

Always mount cylinders using the largest possible high tensile alloy steel socket head cap screws that can fit in the cylinder mounting holes and torque them to the manufacturer's recommendations for their size.

**2.5 Port Fittings** – Hydraulic cylinders applied with meter out or deceleration circuits are subject to intensified pressure at piston rod end. The rod end pressure is approximately equal to:

$$\frac{\text{operating pressure} \times \text{effective cap end area}}{\text{effective rod end piston area}}$$

Contact your connector supplier for the pressure rating of individual connectors.

#### 3.0 Cylinder and Accessories Installation and Mounting

##### 3.1 Installation

**3.1.1** – Cleanliness is an important consideration, and cylinders are shipped with the ports plugged to protect them from contaminants entering the ports. These plugs should not be removed until the piping is to be installed. Before making the connection to the cylinder ports, piping should be thoroughly cleaned to remove all chips or burrs which might have resulted from threading or flaring operations.

## Safety Guide

**3.1.2** – Cylinders operating in an environment where air drying materials are present such as fast-drying chemicals, paint, or weld splatter, or other hazardous conditions such as excessive heat, should have shields installed to prevent damage to the piston rod and piston rod seals.

**3.1.3** – Proper alignment of the cylinder piston rod and its mating component on the machine should be checked in both the extended and retracted positions. Improper alignment will result in excessive rod gland and/or cylinder bore wear. On fixed mounting cylinders attaching the piston rod while the rod is retracted will help in achieving proper alignment.

**3.1.4** – Sometimes it may be necessary to rotate the piston rod in order to thread the piston rod into the machine member. This operation must always be done with zero pressure being applied to either side of the piston. Failure to follow this procedure may result in loosening the piston to rod-threaded connection. In some rare cases the turning of the piston rod may rotate a threaded piston rod gland and loosen it from the cylinder head. Confirm that this condition is not occurring. If it does, re-tighten the piston rod gland firmly against the cylinder head.

For double rod cylinders it is also important that when attaching or detaching the piston rod from the machine member that the torque be applied to the piston rod end of the cylinder that is directly attaching to the machine member with the opposite end unrestrained. If the design of the machine is such that only the rod end of the cylinder opposite to where the rod attaches to the machine member can be rotated, consult the factory for further instructions.

### 3.2 Mounting Recommendations

**3.2.1** – Always mount cylinders using the largest possible high tensile alloy steel socket head screws that can fit in the cylinder mounting holes and torque them to the manufacturer's recommendations for their size.

**3.2.2** – Side-Mounted Cylinders – In addition to the mounting bolts, cylinders of this type should be equipped with thrust keys or dowel pins located so as to resist the major load.

**3.2.3** – Tie Rod Mounting – Cylinders with tie rod mountings are recommended for applications where mounting space is limited. The standard tie rod extension is shown as BB in dimension tables. Longer or shorter extensions can be supplied. Nuts used for this mounting style should be torqued to the same value as the tie rods for that bore size.

**3.2.4** – Flange Mount Cylinders – The controlled diameter of the rod gland extension on head end flange mount cylinders can be used as a pilot to locate the cylinders in relation to the machine. After alignment has been obtained, the flanges may be drilled for pins or dowels to prevent shifting.

**3.2.5** – Trunnion Mountings – Cylinders require lubricated bearing blocks with minimum bearing clearances. Bearing blocks should be carefully aligned and rigidly mounted so the trunnions will not be subjected to bending moments. The rod end should also be pivoted with the pivot pin in line and parallel to axis of the trunnion pins.

**3.2.6** – Clevis Mountings – Cylinders should be pivoted at both ends with centerline of pins parallel to each other. After cylinder is mounted, be sure to check to assure that the cylinder is free to swing through its working arc without interference from other machine parts.

## 4.0 Cylinder and Accessories Maintenance, Troubleshooting and Replacement

**4.1 Storage** – At times cylinders are delivered before a customer is ready to install them and must be stored for a period of time. When storage is required the following procedures are recommended.

**4.1.1** – Store the cylinders in an indoor area which has a dry, clean and noncorrosive atmosphere. Take care to protect the cylinder from both internal corrosion and external damage.

**4.1.2** – Whenever possible cylinders should be stored in a vertical position (piston rod up). This will minimize corrosion due to possible condensation which could occur inside the cylinder. This will also minimize seal damage.

**4.1.3** – Port protector plugs should be left in the cylinder until the time of installation.

**4.1.4** – If a cylinder is stored full of hydraulic fluid, expansion of the fluid due to temperature changes must be considered. Installing a check valve with free flow out of the cylinder is one method.

**4.1.5** – When cylinders are mounted on equipment that is stored outside for extended periods, exposed unpainted surfaces, e.g. piston rod, must be coated with a rust-inhibiting compound to prevent corrosion.

### 4.2 Cylinder Trouble Shooting

#### 4.2.1 – External Leakage

**4.2.1.1** – Rod seal leakage can generally be traced to worn or damaged seals. Examine the piston rod for dents, gouges or score marks, and replace piston rod if surface is rough.

Rod seal leakage could also be traced to gland wear. If clearance is excessive, replace rod bushing and seal. Rod seal leakage can also be traced to seal deterioration. If seals are soft or gummy or brittle, check compatibility of seal material with lubricant used if air cylinder, or operating fluid if hydraulic cylinder. Replace with seal material, which is compatible with these fluids. If the seals are hard or have lost elasticity, it is usually due to exposure to temperatures in excess of 165°F. (+74°C). Shield the cylinder from the heat source to limit temperature to 350°F. (+177°C.) and replace with fluorocarbon seals.

**4.2.1.2** – Cylinder body seal leak can generally be traced to loose tie rods. Torque the tie rods to manufacturer's recommendation for that bore size.

Excessive pressure can also result in cylinder body seal leak. Determine maximum pressure to rated limits. Replace seals and retorque tie rods as in paragraph above. Excessive pressure can also result in cylinder body seal leak. Determine if the pressure rating of the cylinder has been exceeded. If so, bring the operating pressure down to the rating of the cylinder and have the tie rods replaced.

Pinched or extruded cylinder body seal will also result in a leak. Replace cylinder body seal and retorque as in paragraph above.

Cylinder body seal leakage due to loss of radial squeeze which shows up in the form of flat spots or due to wear on the O.D. or I.D. – Either of these are symptoms of normal wear due to high cycle rate or length of service. Replace seals as per paragraph above.

#### 4.2.2 – Internal Leakage

**4.2.2.1** – Piston seal leak (by-pass) 1 to 3 cubic inches per minute leakage is considered normal for piston ring construction. Virtually no static leak with lipseal type seals on piston should be expected. Piston seal wear is a usual cause of piston seal leakage. Replace seals as required.

**4.2.2.2** – With lipseal type piston seals excessive back pressure due to over-adjustment of speed control valves could be a direct cause of rapid seal wear. Contamination in a hydraulic system can result in a scored cylinder bore, resulting in rapid seal wear. In either case, replace piston seals as required.

**4.2.2.3** – What appears to be piston seal leak, evidenced by the fact that the cylinder drifts, is not always traceable to the piston. To make sure, it is suggested that one side of the cylinder piston be pressurized and the fluid line at the opposite port be disconnected. Observe leakage. If none is evident, seek the cause of cylinder drift in other component parts in the circuit.

#### 4.2.3 – Cylinder Fails to Move the Load

**4.2.3.1** – Pneumatic or hydraulic pressure is too low. Check the pressure at the cylinder to make sure it is to circuit requirements.

**4.2.3.2** – Piston Seal Leak – Operate the valve to cycle the cylinder and observe fluid flow at valve exhaust ports at end of cylinder stroke. Replace piston seals if flow is excessive.

**4.2.3.3** – Cylinder is undersized for the load – Replace cylinder with one of a larger bore size.

#### 4.3 Erratic or Chatter Operation

**4.3.1** – Excessive friction at rod gland or piston bearing due to load misalignment – Correct cylinder-to-load alignment.

**4.3.2** – Cylinder sized too close to load requirements – Reduce load or install larger cylinder.

**4.3.3** – Erratic operation could be traced to the difference between static and kinetic friction. Install speed control valves to provide a back pressure to control the stroke.

**4.4 Cylinder Modifications, Repairs, or Failed Component** – Cylinders as shipped from the factory are not to be disassembled and or modified. If cylinders require modifications, these modifications must be done at company locations or by The Company's certified facilities. The Cylinder Division Engineering Department must be notified in the event of a mechanical fracture or permanent deformation of any cylinder component (excluding seals). This includes a broken piston rod, tie rod, mounting accessory or any other cylinder component. The notification should include all operation and application details. This information will be used to provide an engineered repair that will prevent recurrence of the failure.

It is allowed to disassemble cylinders for the purpose of replacing seals or seal assemblies. However, this work must be done by strictly following all the instructions provided with the seal kits.

## Offer of Sale

The items described in this document and other documents and descriptions provided by Parker Hannifin Corporation, its subsidiaries and its authorized distributors ("Seller") are hereby offered for sale at prices to be established by Seller. This offer and its acceptance by any customer ("Buyer") shall be governed by all of the following Terms and Conditions. Buyer's order for any item described in its document, when communicated to Seller verbally, or in writing, shall constitute acceptance of this offer. All goods or work described will be referred to as "Products".

- 1. Terms and Conditions.** Seller's willingness to offer Products, or accept an order for Products, to or from Buyer is subject to these Terms and Conditions or any newer version of the terms and conditions found on-line at [www.parker.com/saleterms/](http://www.parker.com/saleterms/). Seller objects to any contrary or additional terms or conditions of Buyer's order or any other document issued by Buyer.
- 2. Price Adjustments; Payments.** Prices stated on Seller's quote or other documentation offered by Seller are valid for 30 days, and do not include any sales, use, or other taxes unless specifically stated. Unless otherwise specified by Seller, all prices are F.C.A. Seller's facility (INCOTERMS 2010). Payment is subject to credit approval and is due 30 days from the date of invoice or such other term as required by Seller's Credit Department, after which Buyer shall pay interest on any unpaid invoices at the rate of 1.5% per month or the maximum allowable rate under applicable law.
- 3. Delivery Dates; Title and Risk; Shipment.** All delivery dates are approximate and Seller shall not be responsible for any damages resulting from any delay. Regardless of the manner of shipment, title to any products and risk of loss or damage shall pass to Buyer upon placement of the products with the shipment carrier at Seller's facility. Unless otherwise stated, Seller may exercise its judgment in choosing the carrier and means of delivery. No deferral of shipment at Buyers' request beyond the respective dates indicated will be made except on terms that will indemnify, defend and hold Seller harmless against all loss and additional expense. Buyer shall be responsible for any additional shipping charges incurred by Seller due to Buyer's acts or omissions.
- 4. Warranty.** Seller warrants that the Products sold hereunder shall be free from defects in material or workmanship for a period of twelve months from the date of delivery to Buyer or 2,000 hours of normal use, whichever occurs first. The prices charged for Seller's products are based upon the exclusive limited warranty stated above, and upon the following disclaimer: **DISCLAIMER OF WARRANTY: THIS WARRANTY COMPRISES THE SOLE AND ENTIRE WARRANTY PERTAINING TO PRODUCTS PROVIDED HEREUNDER. SELLER DISCLAIMS ALL OTHER WARRANTIES, EXPRESS AND IMPLIED, INCLUDING DESIGN, MERCHANTABILITY AND FITNESS FOR A PARTICULAR PURPOSE.**
- 5. Claims; Commencement of Actions.** Buyer shall promptly inspect all Products upon delivery. No claims for shortages will be allowed unless reported to the Seller within 10 days of delivery. No other claims against Seller will be allowed unless asserted in writing within 30 days after delivery. Buyer shall notify Seller of any alleged breach of warranty within 30 days after the date the defect is or should have been discovered by Buyer. Any action based upon breach of this agreement or upon any other claim arising out of this sale (other than an action by Seller for an amount due on any invoice) must be commenced within 12 months from the date of the breach without regard to the date breach is discovered.
- 6. LIMITATION OF LIABILITY.** UPON NOTIFICATION, SELLER WILL, AT ITS OPTION, REPAIR OR REPLACE A DEFECTIVE PRODUCT, OR REFUND THE PURCHASE PRICE. **IN NO EVENT SHALL SELLER BE LIABLE TO BUYER FOR ANY SPECIAL, INDIRECT, INCIDENTAL OR CONSEQUENTIAL DAMAGES ARISING OUT OF, OR AS THE RESULT OF, THE SALE, DELIVERY, NON-DELIVERY, SERVICING, USE OR LOSS OF USE OF THE PRODUCTS OR ANY PART THEREOF, OR FOR ANY CHARGES OR EXPENSES OF ANY NATURE INCURRED WITHOUT SELLER'S WRITTEN CONSENT, EVEN IF SELLER HAS BEEN NEGLIGENT, WHETHER IN CONTRACT, TORT OR OTHER LEGAL THEORY. IN NO EVENT SHALL SELLER'S LIABILITY UNDER ANY CLAIM MADE BY BUYER EXCEED THE PURCHASE PRICE OF THE PRODUCTS.**
- 7. User Responsibility.** The user, through its own analysis and testing, is solely responsible for making the final selection of the system and Product and assuring that all performance, endurance, maintenance, safety and warning requirements of the application are met. The user must analyze all aspects of the application and follow applicable industry standards and Product information. If Seller provides Product or system options, the user is responsible for determining that such data and specifications are suitable and sufficient for all applications and reasonably foreseeable uses of the Products or systems.
- 8. Loss to Buyer's Property.** Any designs, tools, patterns, materials, drawings, confidential information or equipment furnished by Buyer or any other items which become Buyer's property, may be considered obsolete and may be destroyed by Seller after two consecutive years have elapsed without Buyer ordering the items manufactured using such property. Seller shall not be responsible for any loss or damage to such property while it is in Seller's possession or control.
- 9. Special Tooling.** A tooling charge may be imposed for any special tooling, including without limitation, dies, fixtures, molds and patterns, acquired to manufacture Products. Such special tooling shall be and remain Seller's property notwithstanding payment of any charges by Buyer. In no event will Buyer acquire any interest in apparatus belonging to Seller which is utilized in the manufacture of the Products, even if such apparatus has been specially converted or adapted for such manufacture and notwithstanding any charges paid by Buyer. Unless otherwise agreed, Seller shall have the right to alter, discard or otherwise dispose of any special tooling or other property in its sole discretion at any time.
- 10. Buyer's Obligation; Rights of Seller.** To secure payment of all sums due or otherwise, Seller shall retain a security interest in the goods delivered and this agreement shall be deemed a Security Agreement under the Uniform Commercial Code. Buyer authorizes Seller as its attorney to execute and file on Buyer's behalf all documents Seller deems necessary to perfect its security interest.
- 11. Improper use and Indemnity.** Buyer shall indemnify, defend, and hold Seller harmless from any claim, liability, damages, lawsuits, and costs (including attorney fees), whether for personal injury, property damage, patent, trademark or copyright

infringement or any other claim, brought by or incurred by Buyer, Buyer's employees, or any other person, arising out of: (a) improper selection, improper application or other misuse of Products purchased by Buyer from Seller; (b) any act or omission, negligent or otherwise, of Buyer; (c) Seller's use of patterns, plans, drawings, or specifications furnished by Buyer to manufacture Product; or (d) Buyer's failure to comply with these terms and conditions. Seller shall not indemnify Buyer under any circumstance except as otherwise provided.

- 12. Cancellations and Changes.** Orders shall not be subject to cancellation or change by Buyer for any reason, except with Seller's written consent and upon terms that will indemnify, defend and hold Seller harmless against all direct, incidental and consequential loss or damage. Seller may change product features, specifications, designs and availability with notice to Buyer.
- 13. Limitation on Assignment.** Buyer may not assign its rights or obligations under this agreement without the prior written consent of Seller.
- 14. Force Majeure.** Seller does not assume the risk and shall not be liable for delay or failure to perform any of Seller's obligations by reason of circumstances beyond the reasonable control of Seller (hereinafter "Events of Force Majeure") Events of Force Majeure shall include without limitation: accidents, strikes or labor disputes, acts of any government or government agency, acts of nature, delays or failures in delivery from carriers or suppliers, shortages of materials, or any other cause beyond Seller's reasonable control.
- 15. Waiver and Severability.** Failure to enforce any provision of this agreement will not waive that provision nor will any such failure prejudice Seller's right to enforce that provision in the future. Invalidation of any provision of this agreement by legislation or other rule of law shall not invalidate any other provision herein. The remaining provisions of this agreement will remain in full force and effect.
- 16. Termination.** Seller may terminate this agreement for any reason and at any time by giving Buyer thirty (30) days written notice of termination. Seller may immediately terminate this agreement, in writing, if Buyer: (a) commits a breach of any provision of this agreement (b) appointments a trustee, receiver or custodian for all or any part of Buyer's property (c) files a petition for relief in bankruptcy on its own behalf, or by a third party (d) makes an assignment for the benefit of creditors, or (e) the dissolves or liquidates all or a majority of its assets.
- 17. Governing Law.** This agreement and the sale and delivery of all Products hereunder shall be deemed to have taken place in and shall be governed and construed in accordance with the laws of the State of Ohio, as applicable to contracts executed and wholly performed therein and without regard to conflicts of laws principles. Buyer irrevocably agrees and consents to the exclusive jurisdiction and venue of the courts of Cuyahoga County, Ohio with respect to any dispute, controversy or claim arising out of or relating to this agreement.
- 18. Indemnity for Infringement of Intellectual Property Rights.** Seller shall have no liability for infringement of any patents, trademarks, copyrights, trade dress, trade secrets or similar rights except as provided in this Section. Seller will defend and indemnify Buyer against allegations of infringement of U.S. patents, U.S. trademarks, copyrights, trade dress and trade secrets ("Intellectual Property Rights"). Seller will defend at its expense and will pay the cost of any settlement or damages awarded in an action brought against Buyer based on an allegation that a Product sold pursuant to this Agreement infringes the Intellectual Property Rights of a third party. Seller's obligation to defend and indemnify Buyer is contingent on Buyer notifying Seller within ten (10) days after Buyer becomes aware of such allegations of infringement, and Seller having sole control over the defense of any allegations or actions including all negotiations for settlement or compromise. If a Product is subject to a claim that it infringes the Intellectual Property Rights of a third party, Seller may, at its sole expense and option, procure for Buyer the right to continue using the Product, replace or modify the Product so as to make it noninfringing, or offer to accept return of the Product and return the purchase price less a reasonable allowance for depreciation. Notwithstanding the foregoing, Seller shall have no liability for claims of infringement based on information provided by Buyer, or directed to Products delivered hereunder for which the designs are specified in whole or part by Buyer, or infringements resulting from the modification, combination or use in a system of any Product sold hereunder. The foregoing provisions of this Section shall constitute Seller's sole and exclusive liability and Buyer's sole and exclusive remedy for infringement of Intellectual Property Rights.
- 19. Entire Agreement.** This agreement contains the entire agreement between the Buyer and Seller and constitutes the final, complete and exclusive expression of the terms of sale. All prior or contemporaneous written or oral agreements or negotiations with respect to the subject matter are herein merged.
- 20. Compliance with Law, U. K. Bribery Act and U.S. Foreign Corrupt Practices Act.** Buyer agrees to comply with all applicable laws and regulations, including both those of the United Kingdom and the United States of America, and of the country or countries of the Territory in which the Buyer may operate, including without limitation the U. K. Bribery Act, the U.S. Foreign Corrupt Practices Act ("FCPA") and the U.S. Anti-Kickback Act (the "Anti-Kickback Act"), and agrees to indemnify and hold harmless Seller from the consequences of any violation of such provisions by Buyer, its employees or agents. Buyer acknowledges that they are familiar with the provisions of the U. K. Bribery Act, the FCPA and the Anti-Kickback Act, and certifies that Buyer will adhere to the requirements thereof. In particular, Buyer represents and agrees that Buyer shall not make any payment or give anything of value, directly or indirectly to any governmental official, any foreign political party or official thereof, any candidate for foreign political office, or any commercial entity or person, for the purpose of influencing such person to purchase products or otherwise benefit the business of Seller.

02/12





Parker Hannifin Corporation  
**Pneumatic Division**  
135 Quadral Drive  
Wadsworth, OH 44281 USA  
Tel: 330 336 3511  
Fax: 330 334 3335

Applications Engineering  
Phone: 877 321 4PDN  
E-mail: [pdnapps@parker.com](mailto:pdnapps@parker.com)  
Customer Support  
Phone: 877 321 4PDN  
E-mail: [pdncustsvc@parker.com](mailto:pdncustsvc@parker.com)  
Web site: [www.parker.com/pneumatics](http://www.parker.com/pneumatics)

